

**DHW 301P
DHW 301P+**

Dimplex

**Installation and
Operating Instructions**

English



**Domestic hot water
heat pump**

Contents

Warnings	4
Description	6
Scope of supply	7
Storage	7
Transport	7
Unpacking	7
Installation location	8
Connection	9
Commissioning	16
Operation	17
Maintenance	25
Faults	26
Service	33
Technical data	34

1. Warnings

1.1. Intended use

This device is only intended for use as specified by the manufacturer. Any other use beyond that intended by the manufacturer is prohibited. This requires the user to abide by the relevant project planning documents. Please refrain from tampering with or altering the device.

1.2. Important notes

⚠ ATTENTION!

Read these installation and operating instructions before commissioning!

⚠ ATTENTION!

Work on the domestic hot water heat pump is only to be performed by qualified personnel. Observe accident prevention regulations!

⚠ ATTENTION!

The device cover cannot be used for carrying (the cover cannot withstand significant forces).

⚠ ATTENTION!

Once the heat pump has been set up, the chock must be removed from the air intake.

⚠ ATTENTION!

The heat pump may only be transported in an upright position (see "Transport" chapter).

⚠ ATTENTION!

When installing the on-site pipework, ensure that the pipes are not contaminated (flush pipes before connecting the domestic hot water heat pump if necessary).

⚠ ATTENTION!

The domestic hot water heat pump must only be operated when filled with water.

⚠ ATTENTION!

Disconnect the power supply before opening the domestic hot water heat pump; possible fan coasting must be considered.

⚠ ATTENTION!

Risk of injury caused by sharp-edged fins. Fins must not be deformed or damaged.

⚠ ATTENTION!

Disconnect the power supply before opening the device.

1.3. Regulations / safety notes

⚠ ATTENTION!

Read these installation and operating instructions before commissioning.

The domestic hot water heat pump is used exclusively to heat water for domestic use and drinking water within the specified operating temperature limits. Heating of fluids other than domestic water is not permitted. Technical regulations for domestic water installation are to be observed. The nominal pipe widths for the on-site sanitary installation must be determined taking into account the building-specific requirements and the valid directives and regulations. Any necessary safety devices, such as pressure reducing valves, must be installed according to the specific requirements.

The following are not permitted:

- Operating the pump with solvent-based or explosive exhaust air
- Use of exhaust air containing grease, dust or aerosols
- Connecting extractor hoods to the ventilation system

It is not permissible to install the device:

- Outdoors
- In rooms which are exposed to frost
- In rooms subject to high humidity (e.g. bathrooms)
- In rooms with air which is potentially explosive because of gases, vapours or dust

It is not permissible to operate the device

- With an empty cylinder
- During the construction phase of the building

The construction and design of the domestic hot water heat pump complies with all relevant EU directives (see also CE declaration of conformity).

The specialist engineer must ensure that the refrigerant is flushed adequately to allow maintenance and repair work to be carried out on refrigerant circuit components without risk. Refrigerant must be properly handled and disposed of; it must not be released into the environment. The refrigeration circuit is "hermetically sealed" and contains the refrigerant R290. Information on the GWP value and CO₂ equivalent of the refrigerant is available under "Device information". The refrigerant is CFC-free, non-ozone depleting and combustible.

Always disconnect the power supply before carrying out any work on the domestic hot water heat pump.

When connecting the domestic hot water heat pump to the power supply, the relevant country-specific standards must be complied with. Also observe the technical connection requirements of the electrical utility companies.

This heat pump is designed for use in a domestic environment according to Article 1, Paragraph 2 k) of EU directive 2006/42/EC and is thus subject to the requirements of EU directive 2014/35/EU (Low Voltage Directive).

 ATTENTION!

Work on the domestic hot water heat pump is only to be performed by qualified personnel.

2. Description

2.1. General

The domestic hot water heat pump's main components are a domestic hot water cylinder, the components of the refrigerant, air and water circuits and the control, regulation and monitoring devices required for automatic operation.

The domestic hot water heat pump is supplied with electrical energy and uses the heat stored in the intake air for domestic hot water preparation. The optional internal heat exchanger (DHW 301P+) can be connected to additional heat generators such as boilers and solar energy systems. The devices are equipped with an electric heating element as standard (1.2 kW).

The temperature of the intake air from the heat source acts as the reference value for the energy consumption, the domestic hot water preparation heat-up time and domestic hot water temperature. For this reason, an air duct system (DN160, max. length 6 m (flexible pipe max. 12 m rigid pipe) can be connected to the standard spigot of the domestic hot water heat pump for targeted waste heat recovery.

For the heat pump to be operated effectively, air short circuits between the intake air and the outlet air must always be avoided. For example, this can be achieved by using a bend on the intake and outlet side.

Falling outlet air temperatures reduce the heat pump's heat output and increase the heat-up time. In order for the heat pump to be operated economically, the air intake temperature should not fall below 15 °C.

2.2. The electric heating performs the following functions:

- Supplementary heating
The "Boost" setting enables domestic hot water preparation to be carried out with support from the electric heating for a certain period.
- Emergency heating
In the event of a heat pump fault, the domestic hot water supply is maintained by the electric heating.
- Preventative thermal disinfection
Domestic hot water temperatures above 60 °C (up to 65 °C) can be programmed by selecting "ANTI-BACT." in the menu using the operator panel keypad.
- Reheating
Water temperatures over 60 °C are achieved with the electric heating.

2.3. Safety and control devices

The domestic hot water heat pump is equipped with the following safety devices:

High pressure switch (HP)

The high pressure switch protects the heat pump against unacceptably high operating pressure in the refrigerant circuit and switches the heat pump off in the event of a fault. The heat pump restarts with a time delay once the pressure in the refrigerant circuit has dropped again.

Safety temperature limiter for electric heating (STL)

The STL prevents unacceptably high temperatures from developing in the domestic hot water cylinder. The electric heating switches off if the set switching value (99 °C) is exceeded.

The electric heating cannot be switched on again until the domestic hot water temperature has decreased to ≤ 90 °C and the reset button on the STL (under flange cover) is pressed (this must only be done by qualified personnel).

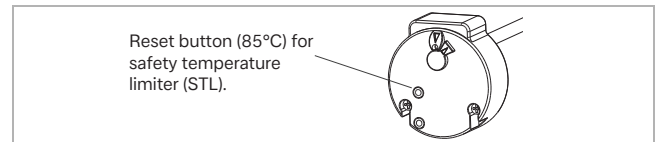

3. Scope of supply

- 1 Domestic hot water heat pump
- 1 Documentation pouch with the following contents:
 - 1 Installation and operating instructions
 - 1 Transport case

4. Storage

i NOTE

The permissible transport and storage temperature for the domestic hot water heat pump is between -5 °C and +35 °C.

5. Transport

i NOTE

The hood of the domestic hot water heat pump must not be used as a transport aid.

i NOTE

No other objects are to be stored on the cardboard packaging. This is particularly important for transportation by truck. Non-compliance can lead to destruction of the cover or the refrigeration circuit.

i NOTE

Maximum tilt angle 30°

Permissible transport position:

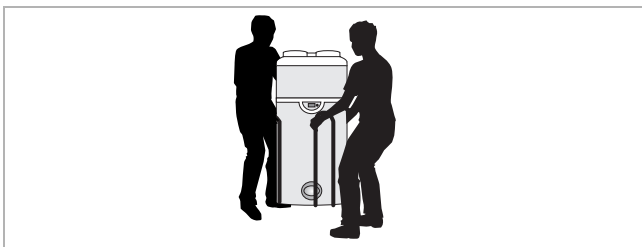
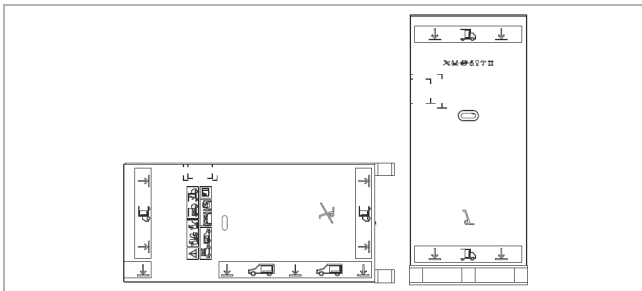

Impermissible transport position:

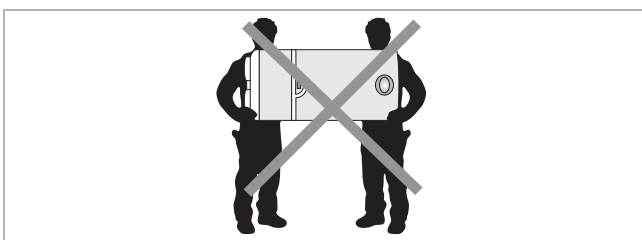
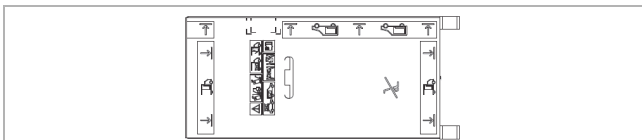

i NOTE

All other transport positions are prohibited.

i NOTE

Transporting the device in a horizontal position may permanently destroy the components of the heat pump refrigeration circuit.

i NOTE

Risk of tipping over! Centre of gravity moved upwards. Handle with care!

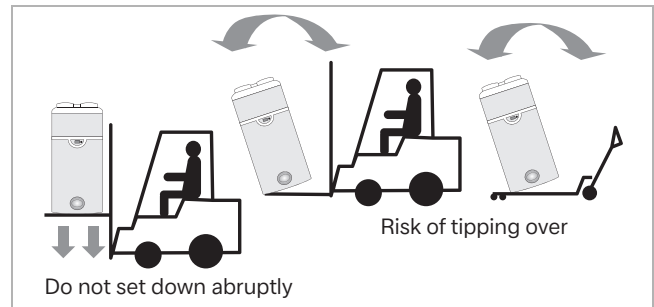

i NOTE

After installing the domestic hot water heat pump in its installation location, wait 60 minutes before commissioning.

6. Unpacking

Remove the cardboard packaging. Ideally, remove it upwards or carefully cut the packaging with a knife. Remove the centring holders and spacers fitted around the heat pump.

Remove the document pack and transport case and store them securely.

Loosen the transport screw under the pallet using a suitable tool.

Use to transport case to transport the heat pump to the final installation location.

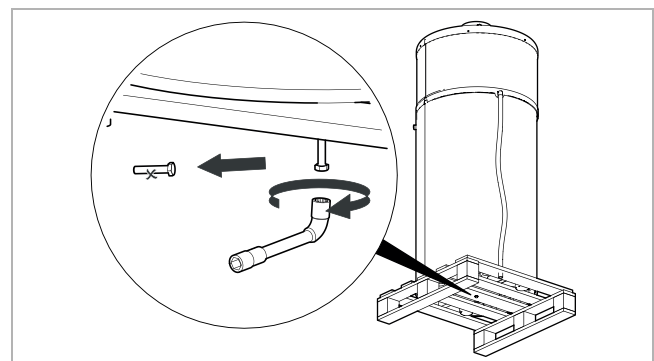

Remove the transport and holding wedges for the compressor by lifting them upwards.

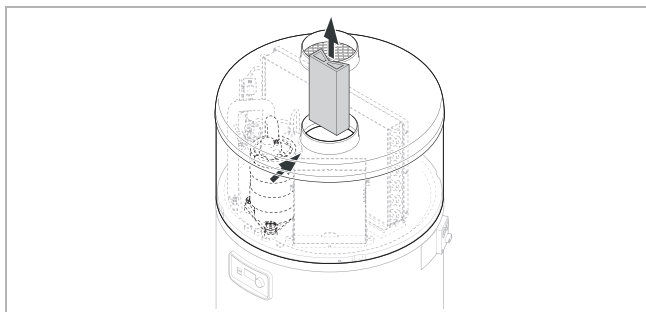

i NOTE

The transport case should be kept away from small children. There is a risk of suffocation.

7. Installation location

7.1. Selecting the installation location

⚠ ATTENTION!

Take the following into account during installation: The device must not be installed close to a constant flame or other ignition source to prevent fire damage to the outer casing of the heat pump. The device must be installed so that mechanical damage is avoided.

Installation location criteria:

- The domestic hot water heat pump must be installed in a dry and frost-free room.
- Without an air duct, the appliance must be installed in a room of at least 20 m³.
- Room height min. 2.20 m with bend for intake or air outlet to prevent air short circuit.
- Furthermore, installation and air intake is not permitted in rooms with air which is potentially explosive due to gases, vapours or dust.
- Observe thermal bridges, particularly if a room cooled by the outlet air is directly adjacent to a heated room.
- Condensate drainage (with a siphon) must be provided.
- The air taken in may not be excessively contaminated or contain large amounts of dust.

It is forbidden to install the device as follows:

- Outdoors.
- in rooms with exposure to frost or with a prevailing temperature below 7 °C, even if the device is in operation.
- In very humid rooms with release of high vapour concentrations.
- In rooms where there is a risk of explosion due to the presence of gases, vapours or dust.

- Installation close to bedrooms should be avoided due to heat pump operation (noise).
- Do not install the air intake opening close to a flue gas outlet (minimum distance 0.6 m).
- Do not operate the device with intake air containing solvents or potentially explosive substances.
- The air taken in must not contain grease, dust or aerosols.
- Connect the extractor hood to the air supply.

i NOTE

The device must be installed in a frost and dust free location.

7.2. Arrangement and attachment

To ensure fault-free operation and to allow any maintenance and repair work, minimum clearances of 0.3 m are required on the left and right of the device and 0.4 m to the ceiling (see figure).

The domestic hot water heat pump is connected (as an option) with EPP air ducts, nominal width 160 mm internal, 190 mm external, which must not exceed a total length of 12 m (rigid pipe) or 6 m (flexible pipe). If air ducts are not used, a 90° EPP pipe bend can be fitted on the outlet side for sound optimisation during operation.

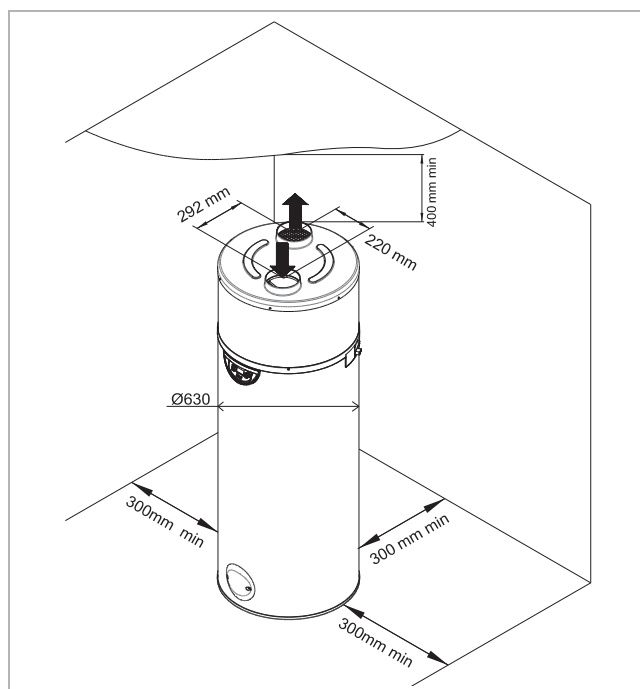

The floor must have an adequate load bearing capacity (weight of the domestic hot water heat pump, filled with 270 l water = 335 kg).

i NOTE

The domestic hot water heat pump must be installed vertically. Otherwise, condensate can overflow and cause water damage.

8. Connection

8.1. Technical air connection

8.1.1. Without air duct

Without an air duct, the device must be installed in a room of at least 20 m³.

If the clear height under the ceiling above the device is less than 60 cm, it is advisable to install a bend on the air outlet and to direct it to the rear or to the sides. The domestic hot water heat pump can also be used in unheated workshops and garages if the parameters listed in chapter 7 "Installation location" are complied with.

The domestic hot water heat pump enables dehumidification and cooling of rooms such as laundry rooms and storerooms.

8.1.2. Intake and air outlet using air duct within buildings

By using an air duct on either the intake or outlet site it is possible to take in air from an adjacent room (e.g. from a laundry room to dehumidify it) or to route the outlet air into an adjacent room (e.g. into a store room to cool it).

A connection with two air ducts is also possible as an option to allow air intake or outlet from or to two different rooms.

8.1.3. Intake or air outlet with outside air

The operating range of the domestic hot water heat pump covers an air temperature range of -7 °C to max. +45 °C. The domestic hot water heat pump takes in heat energy from the outside air. As a result, it is essential to route the air ducts for intake and air outlet outside into the open air to prevent frost damage in the air outlet room during the winter months.

Air duct connection

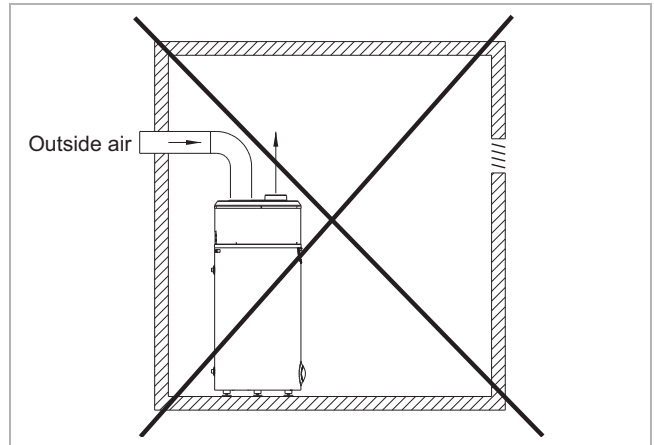
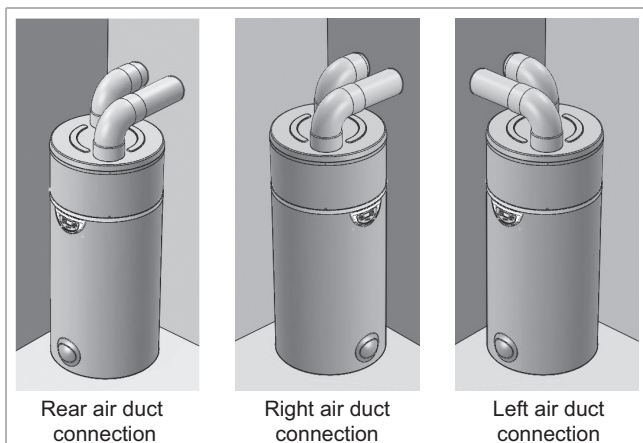

i NOTE

Total length max. at Ø 160:
 6 m for flexible pipe, 12 m for smooth pipe
 1 bend = 1 equivalent metre

The domestic hot water heat pump should be connected using air ducts with an internal diameter of 160 mm.

With a 90° cell foam (EPP) pipe Ø 160 mm the position of the ducts connected to the device can be aligned in all directions (360°).

8.1.4. Accessories for duct connections

The optional accessories available for the duct connection are designed for easy and high-performance connection of the domestic hot water heat pump.

Item 1 and item 2

The air duct 1 (IS R 160 - 370650) and the bends 2 (IS BG 160-90 - 370660) are made of cell foam (EPP), and are semi-rigid, lightweight and heat insulating.

Item 3

They are connected using a connector 3 (IS VM 160 - 370670).

Item	Designation
1	Air duct, straight, Ø 160 mm - length 1 m
2	90° bend, Ø 160 mm
3	Connection sleeve



8.2. Technical water connection

It is essential to install a safety mechanism in the cold water inlet (not supplied – special accessories SVK 825 - 326660).

This safety group must adhere to the national standards and comply with DIN 1988, Part 2; DIN 4753, Part 1 and DIN EN 1488.

The safety group must be installed as close as possible to the cold water inlet on the device and the water flow must not be obstructed by any fittings (valves, pressure reducers etc.).

The drainage outlet from the safety group must be installed in a frost-free environment and have a downward slope.

The drainage outlet from the safety group must be designed in accordance with DTU regulations (standardised technical documents) and must never be blocked. It must be connected via a funnel (at least 20 mm to free air) to a vertical outlet line with a diameter that corresponds at least to that of the connection line of the device.

If the pressure in the cold water inlet is more than 5 bar, a pressure reducing valve must be installed upstream of the safety group at the infeed to the main system (a pressure of 3 to 4 bar is recommended).

We recommend fitting an isolation valve before the safety group.

For systems

- with pipes with a small diameter,
- with a ceramic ball cock

valves must be installed as close as possible to the cocks, or an expansion vessel adapted to the system, to prevent pressure surges.

Connection diagram

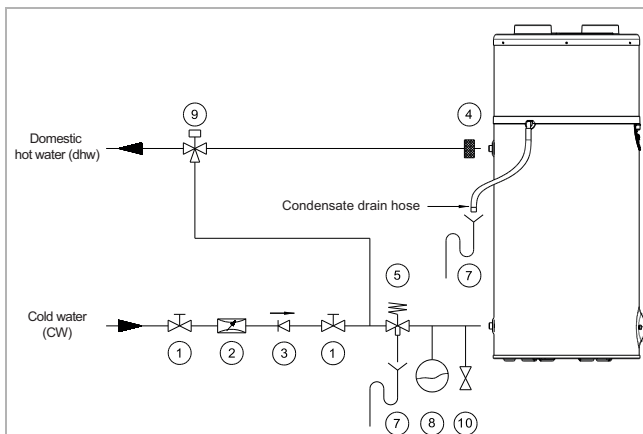

- 1 Isolation valve
- 2 Pressure reducing valve
- 3 Check valve
- 4 Insulating dielectric sleeve, optional
- 5 Diaphragm safety group
- 7 Drainage siphon
- 8 Expansion vessel

- 9 Thermostatic mixer (scalding protection)
- 10 Drain valve

The following materials must be used for the domestic hot water circuit:

- Copper
- Stainless steel
- Brass
- Plastic

i NOTE

Depending on the materials used for the domestic hot water circuit, corrosion-related damage may occur due to incompatibilities.

For this reason, connection of the device to copper domestic hot water pipes must be carried out with a cast or steel connection or using dielectric connections, which prevent any galvanic bridge (iron/copper). The supply line upstream of the device connection to the sanitary installation must be flushed well so that no metal parts or other foreign bodies are transported into the device.

The standards applicable at the installation location must be complied with, in particular with regard to the sanitary conditions and the pressure safety conditions.

i NOTE

The maximum domestic hot water temperature value must not exceed 60 °C at the tapping points. Suitable thermostatic mixers must be installed in the domestic hot water flow to rule out any risk of scalding.

This device works with water that must have a minimum hardness of between 6.5 °dH and 17 °dH. For particularly hard water (total hardness >14 °dH), we recommend using a water softener.

Failure to observe the conditions outlined above will void the warranty for the use of the cylinder (the values apply for a water temperature of 20 °C).

Specific resistance	2200 V.cm < R < 4500 V.cm	
Water hardness	> 1.6 l eq.	> 6.5 °dH < 17 °dH
Free CO2	<15 mg/l	-
Calcium (Ca ⁺⁺)	> 1.6 l eq.	> 4.5 °dH
Sulphate (SO ₄ ⁻⁻)	< 2 l eq.	> 5.6 °dH
Chloride (Cl ⁻)	< 2 l eq.	> 5.6 °dH
Sulphate and chloride (SO ₄ ⁻⁻ + Cl ⁻)	< 3 l eq.	> 5.6 °dH

i NOTE

We strongly advise against using a circulation line. Connection of a circulation line increases the runtime of the heat pump and thus results in higher energy costs.

i NOTE

Failure to observe the above points or to comply with the limit values for the water quality result in all warranty claims being void.

i NOTE

The cylinder has a sacrificial magnesium anode. This must be checked for wear at regular intervals. Replace if necessary (measured value < 0.3A if sacrificial anode is exhausted).

8.3. Installation of a second heat generator (DHW 301P+ only)

8.3.1. Installation diagram

The electrical wiring diagram for integration of a second heat generator can be found in chapter 8.5.3.

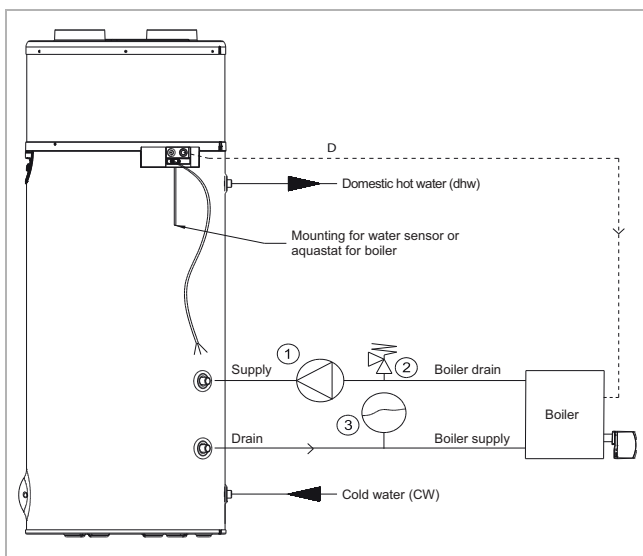

- 1 Circulating pump for 2nd heat generator
- 2 Pressure relief valve
- 3 Expansion vessel

It is possible to control the second heat generator using the floating contact on the domestic hot water heat pump (see chapter 8.3.2) or the controller on the 2nd heat generator using a domestic hot water sensor. This sensor is located on the rear of the cylinder.

8.3.2. Attaching a second heat generator to the domestic hot water heat pump with integrated smooth pipe heat exchanger

- Switch off the device.
- Remove the cover and the hood from the device. This is done by unscrewing the screws on the bottom edge of the hood.
- Remove the black protective cover from the switch box.
- Insert the sensor in the immersion sleeve provided (on read of tank).
- Connect the temperature sensor for the 2nd heat generator to the floating contact at terminals 14 and 15 on the domestic hot water heat pump board (recommended flexible cable 2 x 1.5 mm² with wire end ferrules).
- In this case the alarm output is used for the 2nd heat generator.
- This enables either the integrated heating element or the second heat generator to be selected (e.g. winter/summer operation). By default, the heating element is selected as the second heat generator.

i NOTE

Connecting 230 V at the output for the 2nd heat generator is prohibited. This destroys the board.

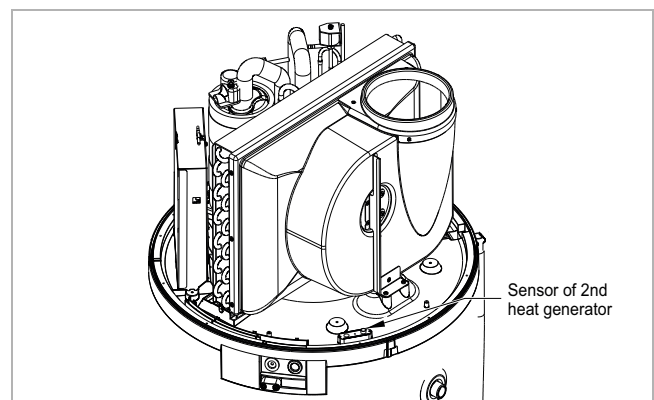
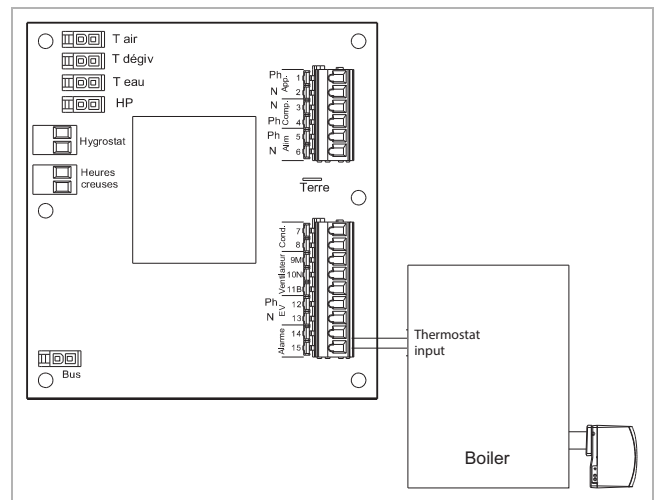

8.3.3. Adjusting the fan speed

With high pressure drops, e.g. caused by excessive pipe lengths, the fan speed needs to be adjusted. The fan speed can be changed using the device electrical connection.

i NOTE

Before adjustment, make sure that the heat pump is disconnected from the power supply.

The grey wire (connecting the 11B output on the circuit board to the 5.5 μF condenser) must be re-routed to the 2-way input for the 5.5 μF condenser. The blue wire is already connected at one contact here.

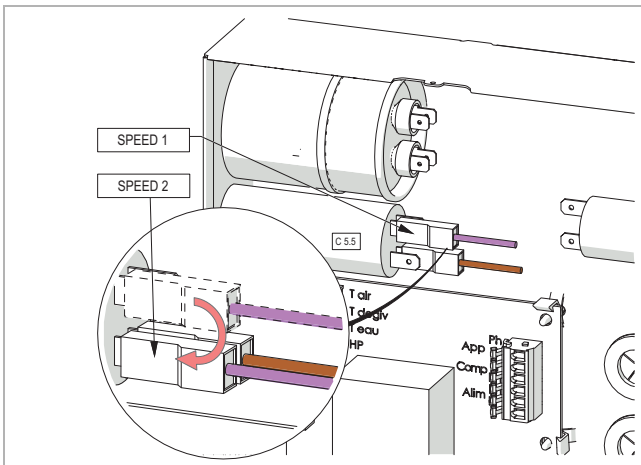

8.4. Condensate drain

The condensate produced must not be drained directly into an outflow through the condensate hose. It must flow through a siphon filled with water.

Do not fit a sleeve connection.

Do not bend the hose.

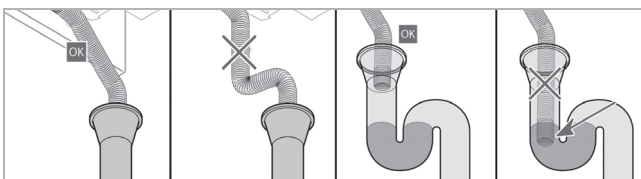

8.5. Electrical connection

i NOTE

Continuous voltage must be applied on the domestic hot water heat pump. The control of the peak and low load times takes place via a cable to be installed separately. Earthing is essential here.

The power supply must be $\sim 230\text{V}$ 50 Hz (1/N/PE).

The power supply must comply with the applicable country-specific requirements and regulations and must be installed by a specialist engineer.

A separating device must be installed on fixed lines in accordance with the installation regulations, which can guarantee a complete shutdown of the heat pump.

The device must be protected as follows:

- By an all-pole circuit breaker, 8 A, with contact opening of at least 3mm
- By a circuit breaker, 8 A, with differential 30 mA.

If the factory fitted connection cable is damaged, it must be replaced by the manufacturer, the manufacturer's after-sales service or a person with comparable qualifications to avoid damage.

8.5.1. Removing the hood

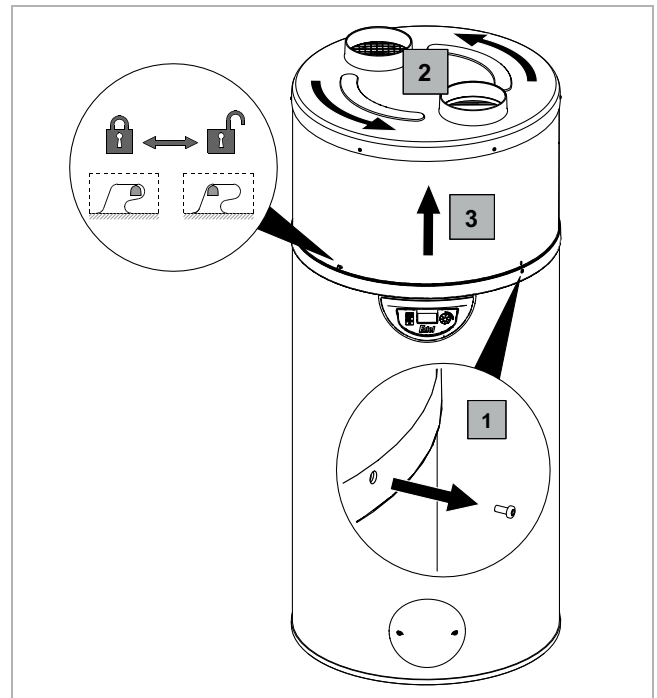

8.5.2. Wiring diagram DHW 301P

- HP High-pressure switch
- C20 Compressor starting condenser
- C2 Fan condenser 2 μ F
- C5.5 Fan condenser 5,5 μ F
- EV Defrost valve
- RE Electric heating element 1200 W
- LTS Heating element safety temperature limiter (STL)
- AqL Heating element thermo controller
- PHP High-pressure switch

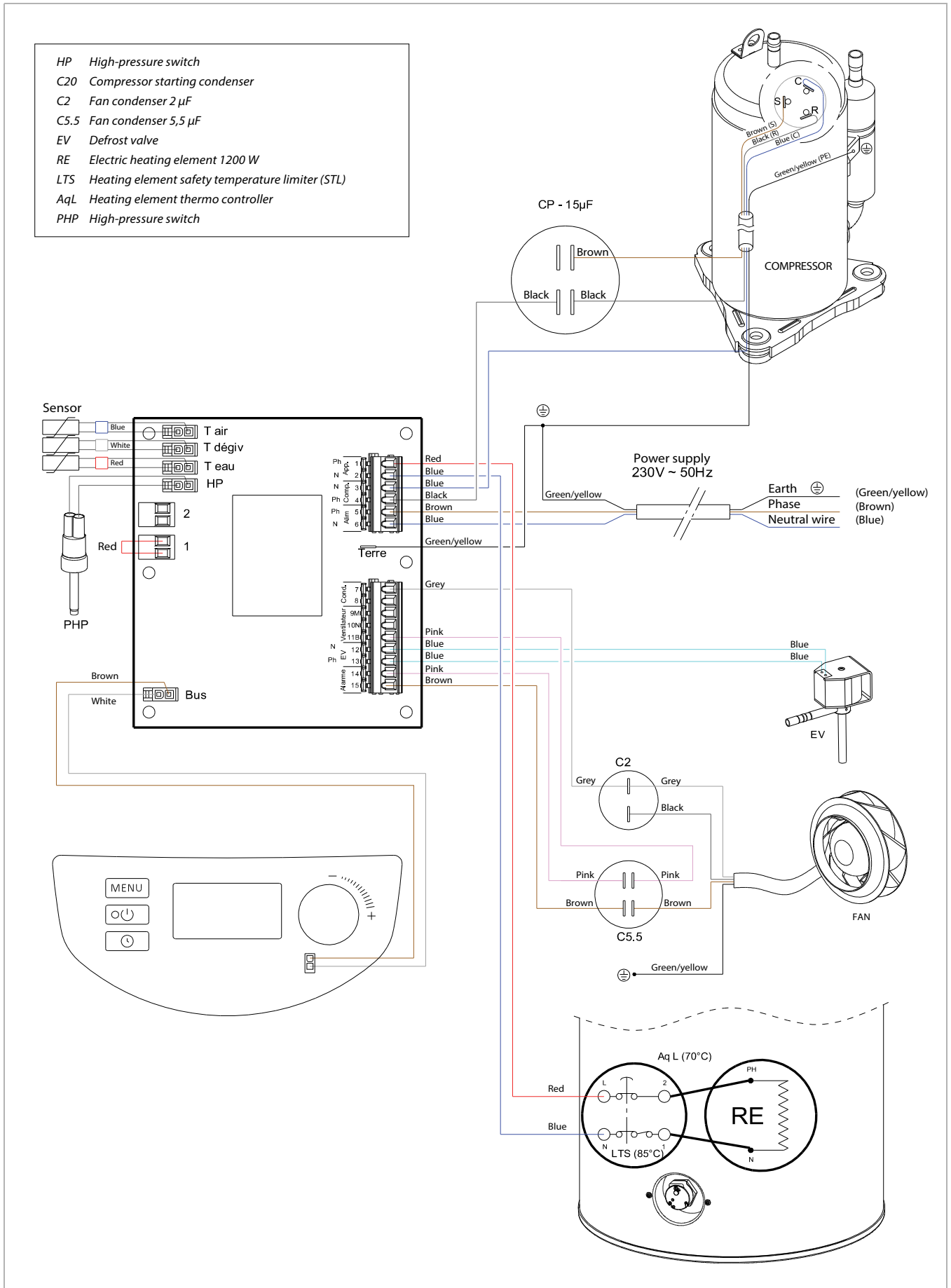

8.5.3. Wiring diagram DHW 301P+ with additional heat exchanger

- HP High-pressure switch
- C20 Compressor starting condenser
- C2 Fan condenser 2 μ F
- C5.5 Fan condenser 5,5 μ F
- EV Defrost valve
- RE Electric heating element 1200 W
- LTS Heating element safety temperature limiter (STL)
- AqL Heating element thermo controller
- PHP High-pressure switch

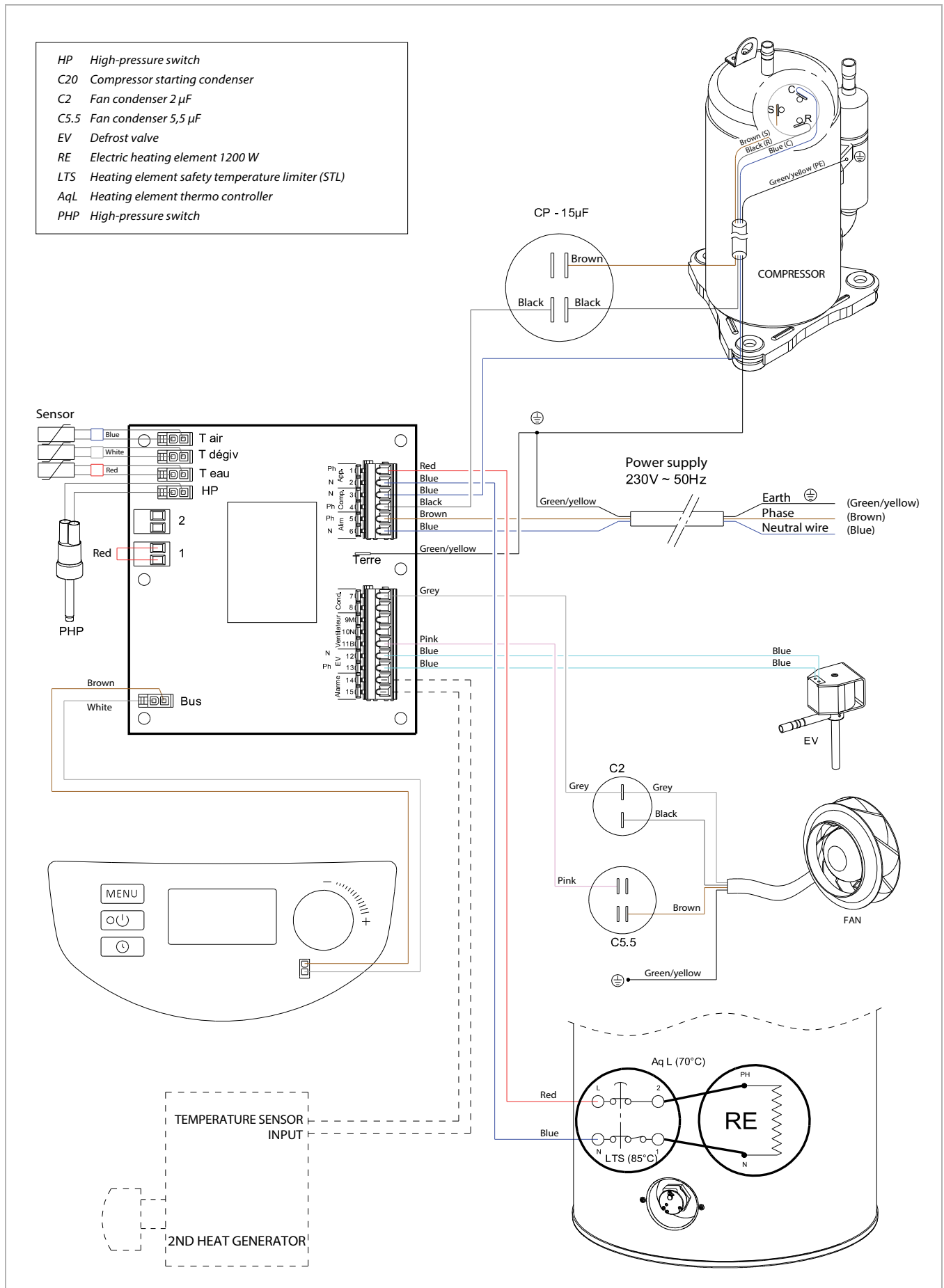

8.5.4. External control

i NOTE

Only one floating connection is permitted. Otherwise, there is a risk that the electrical components may be destroyed. Failure to observe these instructions will void any warranty claims.

i NOTE

Exclusive operation of the domestic hot water heat pump at low load times can lead to impaired functionality.

To enable the “Domestic hot water heat pump” function depending on peak and low load times (full and special tariff) it is not necessary to connect it to the floating contact on the electricity meter.

The time window for operation of the domestic hot water heat pump or the additional heating element can be entered directly on the device operating panel (see “Programming” chapter).

8.5.4.1. Contact for peak and low load times (HP/HC)

The output contact (floating) from the electricity meter can be connected to the domestic hot water heat pump without the need to make complicated settings on the domestic hot water heat pump.

- Contact open = Load shedding
- Contact closed = Normal function

The Load shedding function must be enabled on the device (see “Load shedding” chapter). By default, the heating element does not work at peak load times.

Electrical connection:

- Remove the hood including the nozzle ring.
- Detach the fixing screw for the nozzle ring at the lower collar.
- Remove the cover from the switch box.
- Connect the electricity meter cable to terminal 1 as a floating contact.

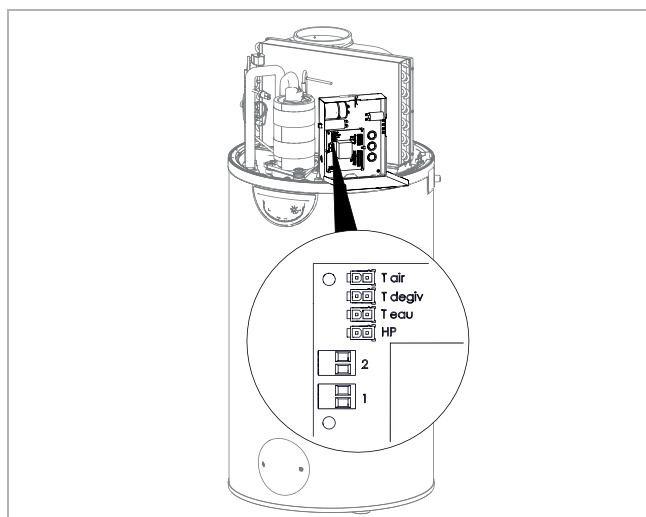

8.5.4.2. Controlled ventilation

The domestic hot water heat pump can be used to continuously ventilate a room even if the heat pump is not performing heating operation.

To ensure that the fan is not running constantly, a humidity or room air sensor is connected to terminal 2 on the board as a floating contact. Refer to the previous chapter for details of the electrical connection procedure.

- Contact open = Fan stopped
- Contact closed = Fan running

The settings for external ventilation control (example for humidity switch: Stego EFR 012) are made using the “FAN MODE 3” option in the menu (see “Fan mode” chapter).

8.5.4.3. Utility company blocking contact

To ensure that the heat pump and/or the electric auxiliary heating is not in operation at peak load times, the utility company blocking contact coming from the electricity meter can be connected to terminal 1 on the circuit board.

- Contact open = Operation of the heat pump and/or auxiliary heating cannot be activated
- Contact closed = Operation of the heat pump and/or auxiliary heating can be activated

When load shedding level 0 or 1 is selected (see “Load shedding” chapter), either only the supplementary electric heating (load shedding = 1) is disabled, or the heat pump and the supplementary electric heating are blocked (load shedding = 0).

Electrical connection:

- Run a 2-core cable (2 x 0.75 mm²) through the cable gland on the rear of the device, feed it into the switch box and connect it to terminal 1. Remove the factory fitted link cable first.

10. Operation

10.1. Operating panel

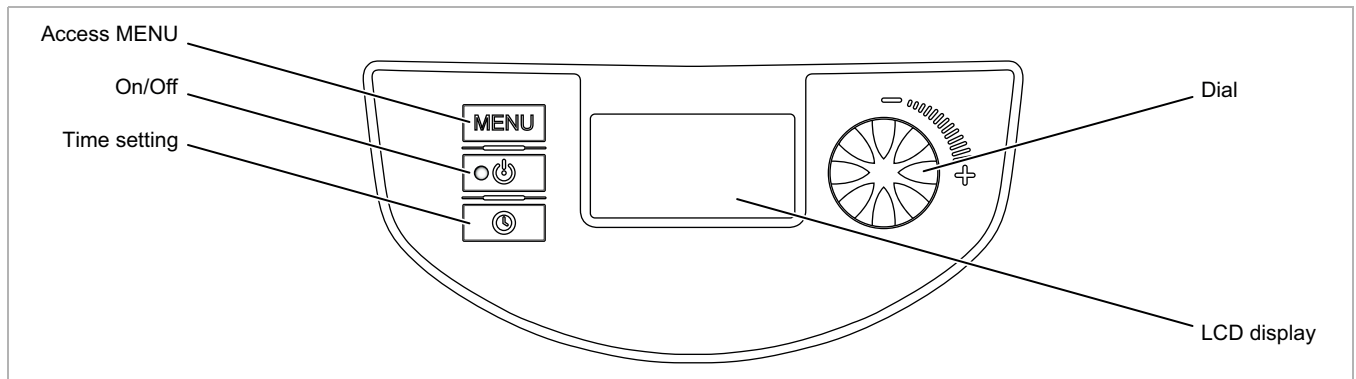

10.2. Meaning of pictograms in LCD display

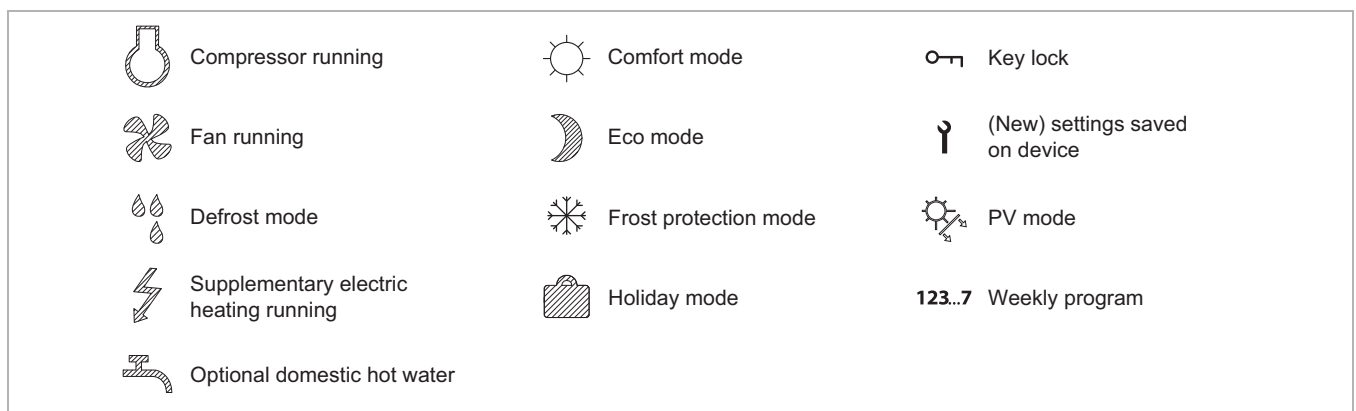

10.3. Operation/Standby

Briefly pressing the button switches on the device.

Pressing and holding the button switches the device to standby mode.

Frost protection is enabled in standby mode.

The domestic hot water heat pump starts automatically at a minimum water temperature of 6 °C and ends heating at a water temperature of max. 12 °C.

10.4. Setting the language

The first time the domestic hot water heat pump is switched on, the language must be selected.

Turn the dial to the left and select the language you want to use. Confirm by pressing. Access to the “LANGUAGE” menu is always possible.

Direct access is by pressing the button.

Turn the dial to open the “LANGUAGE” menu. Set your preferred language and confirm by pressing the button.

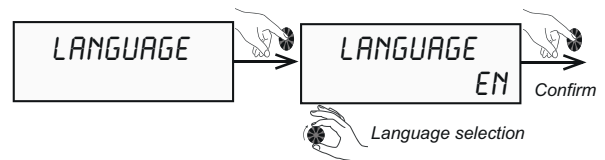

Press the button to return to the home screen.

10.5. Setting the time and date

Direct access is by pressing the  button.

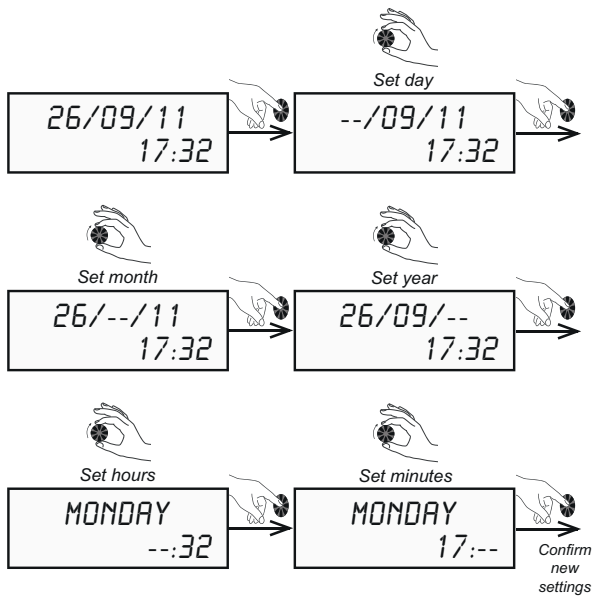

Press the  button to return to the home screen.

10.6. Setting the water temperature

10.6.1. Using without PV entry

i NOTE

The water temperature can be set between 30 °C to 65 °C. Up to 60 °C the water is heated using the heat pump only. Beyond this, up to 65 °C the additional electric heating is activated.

Direct access is by pressing the  button. Turn the dial to open the “TEMP. SETT.” menu. Set the desired domestic hot water temperature and confirm by pressing the button.

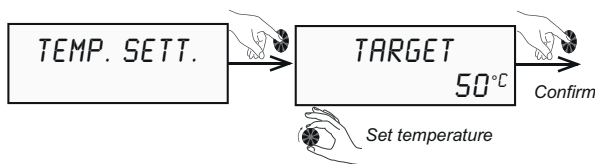

Press the  button to return to the home screen.

i NOTE

From an energy use perspective, the setpoint for the water temperature should not be too high. The water temperature is set to 55 °C by default.

10.6.2. Using with PV yield

If sufficient PV yield is available for self-supply at particular times or day or year, the water temperature can be set to a higher temperature level.

The PV yield can be set either for the heat pump alone (T°PV ECO) or in conjunction with the heating element (T°PV MAX).

Direct access is by pressing the  button.

Turn the dial to open the “TEMP. SETT.” menu. Set the desired domestic hot water temperature and confirm by pressing the button.

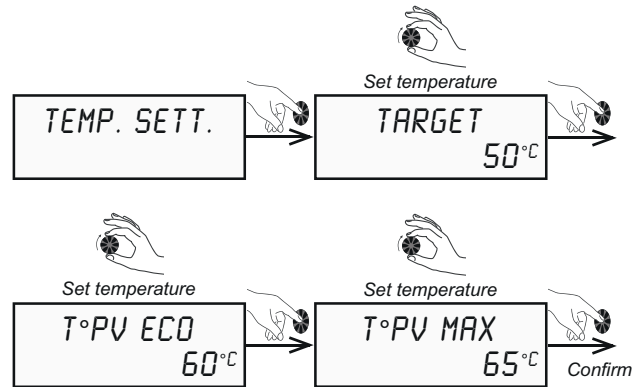

Press the  button to return to the home screen.

Examples of PV use:

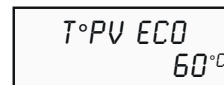

Domestic hot water setting for pure heat pump operation using the PV plant (“PV ECO” mode).

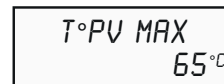

Domestic hot water setting for combined operation of the heat pump and the electric additional heating element using the PV plant (“PV MAX” mode).

10.7. Holiday mode

The “HOLIDAYS” (holiday mode) function can be used to set the device to standby mode to ensure frost protection. This function can be programmed for a period of one to 99 days. After confirmation, the period for holiday mode is enabled.

Direct access is by pressing the **MENU** button. Turn the dial to open the “HOLIDAYS” menu. Set the desired period and confirm by pressing the button.

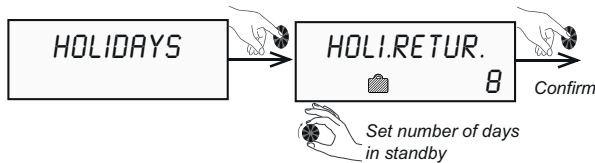

Press the **MENU** button to return to the home screen. The “HOLIDAYS” function ends automatically when the selected number of days has elapsed, at the time when it was enabled. For the entire holiday time, “HOLI. RETUR.” is displayed on the domestic hot water heat pump with a display of the remaining days.

10.8. “Boost” function

The “BOOST” function is used to simultaneously enable both the heat pump and the electric heating element to reduce the heating-up time. The ⚡ symbol flashes on the display.

Direct access is by pressing the **MENU** button. Turn the dial to open the “BOOST” menu. Confirm “YES” by pressing the button.



Press the **MENU** button to return to the home screen. When the “BOOST” function has been enabled, the symbol in the display starts flashing until the desired water temperature is reached. The “Boost” function is automatically disabled as soon as the domestic hot water set temperature is reached.

10.9. Electric mode

In “ELEC. MODE” only the electric heating element is enabled to heat the water.

NOTE

From an energy use perspective, this function should only be used when absolutely essential (e.g. heat pump fault).

Direct access is by pressing the **MENU** button. Turn the dial to open the “ELEC. MODE” menu. Confirm “YES” by pressing the button.

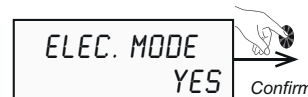

Press the **MENU** button to return to the home screen. When the “ELEC. MODE” function is enabled, the symbol in the display starts flashing.

10.10. Enabling a second heat generator (DHW 301P+ with additional heat exchanger only)

Direct access is by pressing the **MENU** button. Turn the dial to open the “BACKUP” menu. Set the preferred 2nd heat generator (“ELEC. BACKP” or “BOIL. BACKP”) and confirm by pressing the button.

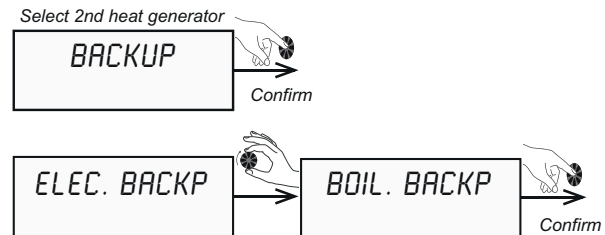

Depending on the second heat generator selected, the ⚡ or ⚙ symbol appears in the display. Press the **MENU** button to return to the home screen.

10.11. Setting a weekly program

The weekly program can be used to set time windows for different operating modes. The operating modes are:

- “F P”: Dehumidify, frost protection mode
- “ECO”: Optimised heat pump operation
- “CONF”: Comfort mode with heat pump and electric additional heating element

In “ECO” mode, use of the supplementary electric heating is not permitted.

Direct access is by pressing and holding the  button.

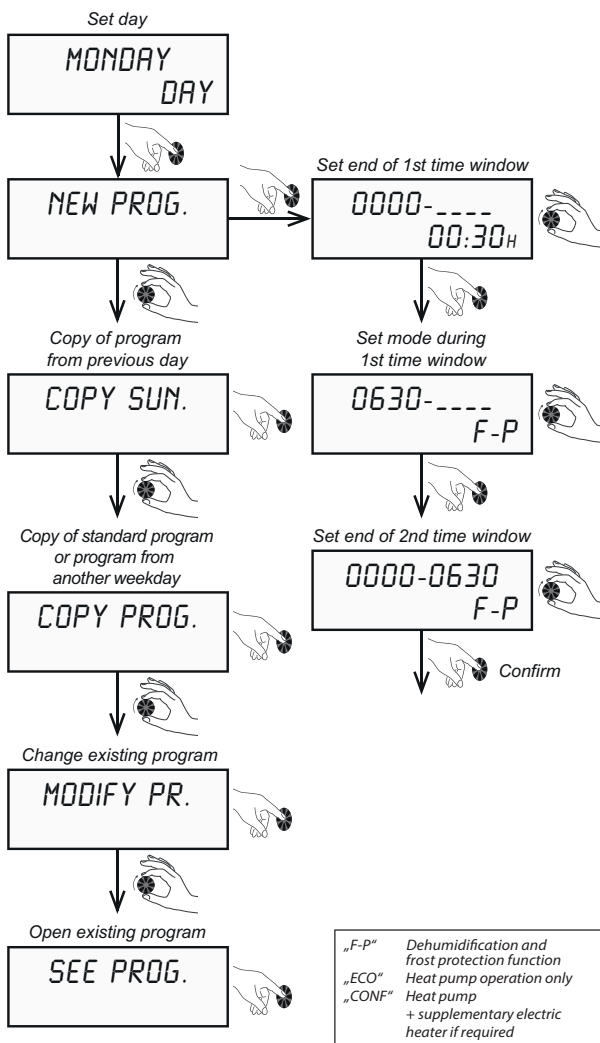

i NOTE
Up to 7 time windows per day are possible, until 24:00 in each case.

i NOTE
The heating-up time of the domestic hot water heat pump depends on the outside temperature. Therefore, appropriate operating times and modes should be selected.

Press the  button to return to the home screen.



10.12. Installer menu

Depending on the system configuration, certain parameters have to be adjusted to optimise the functioning of the domestic hot water heat pump.

Opening the installer menu

Direct access is by pressing the  button.

Turn the dial to open the “INST. MENU” menu.

Simultaneously press and hold the  and  buttons for three seconds until the display shows “PV MODE”.

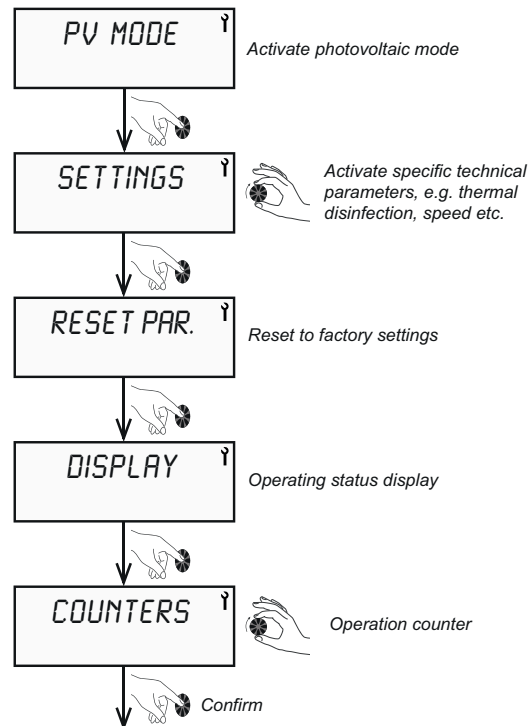

Press the  button to return to the home screen.

10.12.1. Photovoltaic mode

Parameter	Designation	Setting	Factory setting
PV MODE	Enable PV mode	Yes No	No
PRIORITY	Enable the antibacterial / thermal disinfection cycle	Yes No	Yes

If the output from an energy manager / inverter checker is connected to terminals 1 and 2 on the domestic hot water heat pump board, PV mode must be enabled in the menu.

- There are two different options for using the PV yield for the domestic hot water heat pump.
- "PV ECO" = Domestic hot water setting for pure heat pump operation using the PV plant. The maximum water temperature that can be set is 60 °C.
- "PV MAX" = Domestic hot water setting for combined operation of the heat pump and the electric additional heating element using the PV plant mode. The maximum water temperature that can be set is 65 °C.

Direct access is by pressing the **MENU** button.

Turn the dial to open the "INST. MENU" menu. Press the dial to go to the submenu and open the "PV MODE" menu. Confirm "YES" by pressing the button.

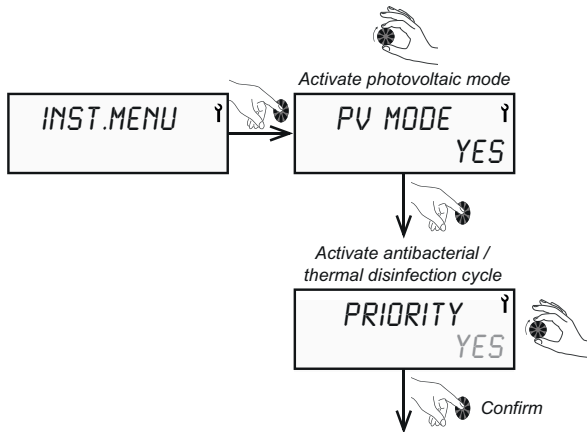

PRIORITY "Yes":

The output signal from the energy manager / inverter checker applied at terminals 1 and 2 takes priority over the settings (e.g. frost protection, weekly program) on the heat pump.

PRIORITY "No":

The output signal from the energy manager / inverter checker applied at terminals 1 and 2 is subordinate to the settings (e.g. frost protection, weekly program) on the heat pump.

Press the **MENU** button to return to the main menu. Next select the "TEMP. SETT." option, turn the dial and set the desired water temperature for "T°PV ECO" or "T°PV MAX".

NOTE

If photovoltaic mode has priority, the domestic hot water is heated during the non-enabled time windows in the weekly program (e.g. in holiday mode and outside the programmed time windows). If you only want the domestic hot water to be heated in the enabled time windows set in the weekly program, set the priority to "No".

NOTE

On the DHW 301P+ with additional heat exchanger, the second heat generator is ignored when feeding in PV power. Only the electric additional heating element is supplied with the power generated by the photovoltaic plant.

Press the **MENU** button to return to the home screen.

10.12.2. Setting the function parameters

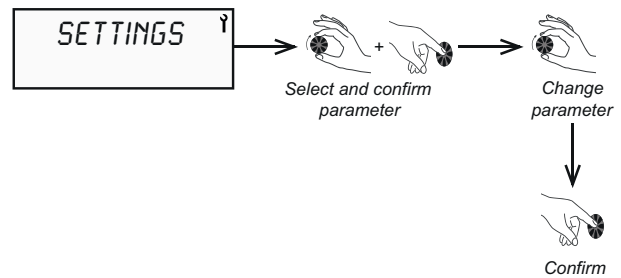

Parameter	Designation	Unit	Setting	Factory setting
ANTI BACT.	Time interval for antibacterial / thermal disinfection function	Days	0-99	0
FAN MODE	Fan mode	Mode	1, 2, 3	1
T°C MINI	Minimum domestic hot water temperature	-	0, 1	0
SHEDDING	Load shedding level	-	0, 1, 2	1
MAX. TIME	Maximum heating-up time	Hours	No, Auto, 1 - 24	No

Press the **MENU** button to return to the home screen.

10.12.2.1. Antibacterial / thermal disinfection cycle "ANTI BACT."

"ANTI BACT." cycle factory setting: "NO"

Water temperature "TEMP. SETT." factory setting: "60 °C"

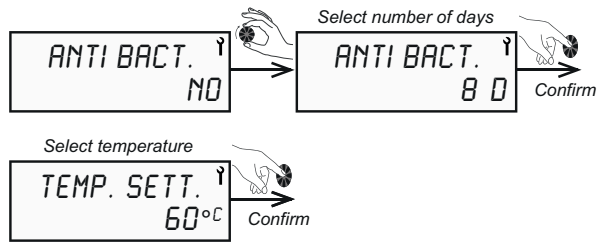

Example setting:

"ANTI BACT.": 8

"TEMP. SETT.": 60 °C

This means that thermal disinfection is performed every 8 days at a water temperature of 60 °C.

i NOTE

The thermal disinfection is always performed at 22:00.

Press the **MENU** button to return to the home screen.

i NOTE

If the setpoint for the domestic hot water is already set to 60 °C (see "Setting the water temperature" chapter), no antibacterial cycle is initiated as it is carried out continuously.

If the thermal disinfection cycle using the additional heating element is blocked by a utility company blocking signal, it is started again in the next release period.

i NOTE

For energy use reasons, thermal disinfection should only be switched on for a longer period of absence of 3 days or more (e.g. holiday).

10.12.2.2. Fan mode "FAN MODE"

"FAN MODE" factory setting: "1"

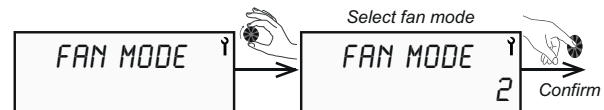

- Mode 1:** Normal operation, automatic fan speed
- Mode 2:** Forced ventilation, maximum fan level
- Mode 3:** Fan speed during heating-up phase and simultaneous external control. e.g. by room or humidity sensor (e.g. Stego EFR 012)

Press the **MENU** button to return to the home screen.

10.12.2.3. Minimum domestic hot water temperature "T°C MINI"

It is possible to enable the supplementary electric heating at the same time as the heat pump to prevent the water temperature falling below the felt comfort temperature of 38 °C. The supplementary electric heating is enabled until the water in the cylinder has reached a temperature of 43 °C.

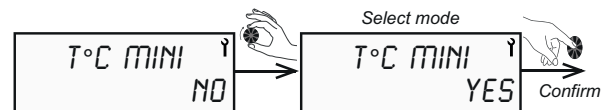

The function is disabled by default.

With load shedding, this function is not enabled or has no effect.

Press the **MENU** button to return to the home screen.

i NOTE

The hysteresis of the domestic hot water heat pump is 5 Kelvin. As soon as the value is below this, the heat pump goes into reheating mode.

10.12.2.4. Load shedding – Enable levels at peak load times “SHEDDING”

If the load shedding contact is active at peak load times, this setting can be used to block the heat pump and/or the additional heating element.

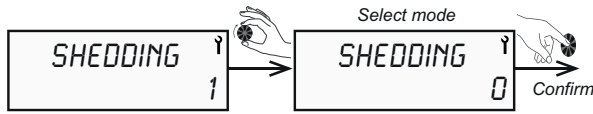

If the load shedding contact is open, the following settings are possible:

- Mode 0:** Heat pump and additional heating element are blocked
- Mode 1:** Function enabled for heat pump only
- Mode 2:** Function enabled for heat pump and additional heating element (= neutralisation of “Peak load times” function).
If the PV function is enabled, this function is disabled. In this case, a time program should be set up (see “Setting a weekly program” chapter).

Press the **MENU** button to return to the home screen.

10.12.2.5. Maximum heating-up time “MAX. TIME”

The maximum heating-up time can be used to adjust the period for complete filling of the cylinder for a specific user. In this case, the heat pump control automatically enables the supplementary electric heating to speed up heating-up of the cylinder.



NOTE
Selecting “MAX. TIME” = “AUTO” limits the heating-up time to 5 hours.

NOTE
For energy use reasons, the heating-up time for complete discharge of the cylinder with domestic hot water should not be less than 7 hours.

This function is disabled by default.

Press the **MENU** button to return to the home screen.

10.12.3. Key lock

Automatic and permanent locking

In the “LOCKING” menu, 3 possible locking options for access to the menus can be set.

In the “INST. MENU”, turn the dial to “LOCKING”.

No: Locking is not enabled. However, manual locking is possible.

To do this, press and hold the **MENU** button for three seconds.

To unlock, press and hold the **MENU** button for three seconds, until “UNLOCK” appears in the display. Confirm “YES” by pressing the button.

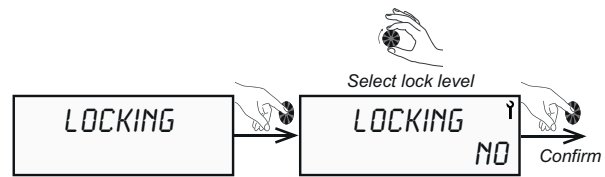

Auto: The key lock is automatically enabled after 60 seconds. To unlock, press and hold the **MENU** button for three seconds, until “UNLOCK” appears in the display. Confirm “YES” by pressing the button.

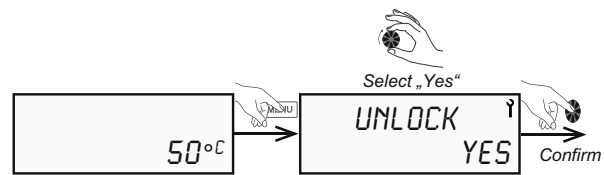

Pro: The key lock is automatically enabled after 5 minutes. To unlock, press and hold the **MENU** button for three seconds, until “UNLOCK” appears in the display. Then simultaneously press and hold the **+** and **+** buttons until “UNLOCK” appears in the display. Confirm “YES” by pressing the button.

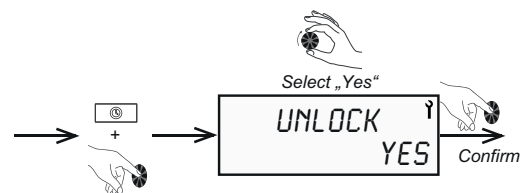

Press for 3 seconds

NOTE
When the key lock is enabled, only fault messages can be reset.

Manual key lock

If no settings have been made in the “LOCKING” menu, you can enable the key lock manually.

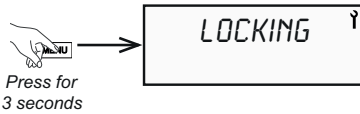

For manual locking, press and hold the **MENU** button for three seconds.

To unlock, press and hold the **MENU** button for three seconds, until “UNLOCK” appears in the display. Confirm “YES” by pressing the button.

10.12.4. Resetting to factory settings

In the “RESET” menu you can reset all set parameters to the factory settings.

In the “INST. MENU”, select the “RESET” menu and confirm “YES” by pressing the button.

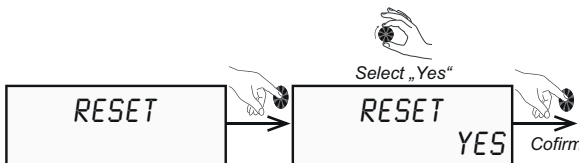

10.12.5. Operating status and settings display “DISPLAY”

In the “DISPLAY” menu you can view various domestic hot water heat pump operating statuses. In the “INST. MENU”, select the “DISPLAY” menu and confirm by pressing the button.

Display	Designation
WATER	Water temperature in the cylinder
AIR INLET	Temperature of the air taken in by the heat pump
T°EVAPOR	Heat pump evaporator temperature (expansion valve output)

The PV function is disabled by default. The following parameters can also be viewed:

SHEDDING	Contact input (terminal 1) Low load times 0 = Contact open 1 = Contact closed
FAN CONTR.	Room or humidity sensor input (terminal 2) 0 = Contact open 1 = Contact closed

If the PV function is enabled, the following parameters are also displayed:

PV ECO	Contact 1 input 0 = Contact open 1 = Contact closed
PV MAX	Contact 2 input 0 = Contact open 1 = Contact closed

10.12.6. Operation counter “COUNTERS”

In the “COUNTERS” menu, the heat pump and electric additional heating element activations can be viewed.

In the “INST. MENU”, select the “COUNTERS” menu and confirm by pressing the button.



Counter 1: Heat pump activations

Counter 2: Electric

heating element activations

Counter 4: Total heat pump and electric heating element activations

11. Maintenance

11.1. General

To ensure fault free functioning and to extend the service life of the device, we recommend having annual inspection and maintenance work carried out by an authorised specialist.

i NOTE

Any work on the domestic hot water heat pump may only be carried out by qualified personnel.

i NOTE

The applicable local safety regulations must be adhered to. Observe country-specific building regulations.

i NOTE

Any work on the refrigeration circuit may only be carried out by qualified personnel with a refrigeration certificate in at least category 1.

i NOTE

Discharging refrigerant into the surrounding air is prohibited.

i NOTE

The refrigerant must be extracted before any work on the refrigeration circuit. Avoid ignition sources in the immediate vicinity during extraction. Do not use cleaning agents containing oil.

i NOTE

De-energize the domestic hot water heat pump before opening.

i NOTE

Before working on the heat pump, check that the fan is stopped.

i NOTE

The function of the electric additional heating element must be checked at regular intervals and any limescale deposits must be removed from the heating elements.

When draining the cylinder, ensure that there is sufficient rear ventilation to avoid any negative pressure in the cylinder.

The following materials and products may not be used:

- Brushes with steel bristles and steel sponges,
- Scouring powder.
- Any product based on sodium or potassium hypochlorite solution or other chlorine derivatives.

During maintenance work or when decommissioning the domestic hot water heat pump, observe the environmental protection regulations with regard to collecting, recycling and disposing of operating materials and components.

i NOTE

The R290 refrigerant in the heat pump circuit poses no risk to the environment, but is flammable.

i NOTE

The R290 refrigerant is odourless and heavier than air.

i NOTE

The pipes of the refrigeration circuit must not be damaged.

i NOTE

Do not work with a naked flame or other ignition sources inside the device.

i NOTE

In the event of a refrigerant leak, disconnect the heat pump from the power supply, ventilate the room thoroughly and contact after-sales service.

When carrying out work on the refrigeration circuit:

- Secure the work area.
- Inform the affected persons of the risks associated with the work being carried out.
- Ensure that the risk of ignition is low.
- Ensure that there are no ignition sources or naked flames in an area of 3 m around the heat pump.
- Avoid working in enclosed, narrow spaces. The work area must be adequately ventilated.
- Check the work area before and during the work with a suitable leak detector.
- Keep a dry powder or CO₂ extinguisher close to the work area.

11.2. Water circuit and condensate drain

Check that the condensate produced is properly drained. The following procedure should be used:

- Remove the hood (see procedure in the “Electrical connection” chapter).
- Ensure that the outlet opening for the condensate drain is not blocked.
- Clean the condensate tray regularly. Deposits from the intake air may collect here.
- Check the condensate hose for soiling and clean if necessary.
- The function of the electric additional heating element must be checked at regular intervals and any limescale deposits must be removed from the heating elements.
- Check all hydraulic connections for leaks.

11.3. Supply and exhaust air

Inspect and clean the evaporator and, if necessary, the supply and exhaust air ducts at least once a year. If air filters are used, their soiling level must be checked regularly. Clean the filters and replace as required.

i NOTE

Risk of injury on sharp edged fan blades! The fan blades must be neither deformed nor damaged.



11.4. Electrical maintenance

During maintenance work, check the electronic components for damage, check that cables and terminals are securely connected, check all electrical components for soiling and clean if necessary.

12. Faults

12.1. Eliminating faults

The heat pump is not working

- Domestic hot water setpoint is higher than water temperature in cylinder.
- Power supply interrupted, green LED on the on button is not lit.
- Device is in holiday mode (display .
- Temperature of intake air or ambient temperature is below -7 °C or above +45 °C (display  - heating element active).
- Functioning is disabled by a programmed time window (display .
- Device is in load shedding mode.
- A fault is shown on display (see “Fault messages” chapter).

No domestic hot water

- Actual domestic hot water consumption is greater than volume of water available in cylinder.
- Programmed time window for operation is too short to completely heat cylinder.
- Programmed water temperature is too low.
- Water circuit is interrupted.

Condensate cannot drain (water under device)

- Condensate drain is soiled or blocked. Clean if necessary. Proceed as follows:
 - Remove hood.
 - Check condensate drain opening for soiling.
- Hose is kinked and is not hanging down.
- Condensate hose does not feed into a collecting vessel or into a drain.
- Domestic hot water heat pump is not standing horizontally.

Supplementary electric heating is not working

- Control is blocked by a utility company blocking contact or is disabled by a weekly program (display .
- Safety thermostat for supplementary electric heating was not triggered due to overtemperature (>85 °C). If this is the case, reset thermostat.
- Check the following before carrying out the reset:
 - Heating element is covered with limescale.
 - Clean heating element and replace if necessary.

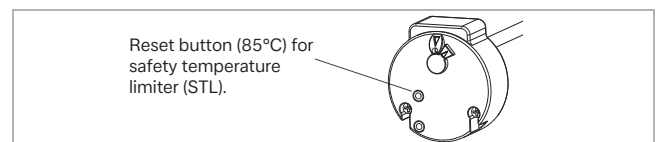

i NOTE

Settings on safety temperature limiter are prohibited.

12.2. Fault messages

This domestic hot water heat pump is a quality product and is designed for fault-free operation. Should a fault

occur, however, it will be indicated on the heat pump display. The following fault messages are possible:

Display	Type of fault	Cause	Measures required	Temporary Function / Resolution
MEMO/BUS	Electronic board faulty. No connection between bus and display unit. User display faulty.	Electrical overvoltage in network. Incorrect wiring of electrical connection (utility company blocking contact, sensor etc.). Damage during transportation.	Replace electronic motherboard. or Replace display.	Domestic hot water heat pump off.
T°AIR	Air intake temperature sensor faulty.	Sensor faulty. Sensor not connected to board. Sensor line damaged.	Replace sensor.	Heat pump off. Supplementary electric heating system heats up water to 43 °C (min. 38 °C)
T°DEFROST	Evaporator sensor faulty.	Sensor faulty. Sensor not connected to board. Sensor line damaged.	Replace sensor.	heat pump off. Supplementary electric heating system heats up water to 43 °C (min. 38 °C)
T°WATER	Domestic hot water sensor in cylinder faulty.	Domestic hot water sensor faulty. Domestic hot water sensor not connected to board. Sensor line damaged.	Replace domestic hot water sensor.	Domestic hot water heat pump off.
CLOCK	Clock	Overvoltage in network. Transport damage.	Set date and time. If setting is not possible, replace board.	The weekly program is no longer followed and the water is kept constantly at the set temperature (provided there is no signal or control device connected at the "external contact" input).
OVER PRESS.	High pressure on heat pump.	No water in cylinder. Water too hot (>75 °C). Domestic hot water sensor not in cylinder. Domestic hot water sensor faulty. Evaporator soiled.	Check whether cylinder is properly filled with water and ventilated. Replace domestic hot water sensor. Check whether the domestic hot water sensor is fitted correctly in immersion sleeve. Carefully clean evaporator (fins) with vacuum cleaner.	Domestic hot water heat pump off. Manual restart of domestic hot water heat pump required.

Display	Type of fault	Cause	Measures required	Temporary Function / Resolution
FREQ.DEFRO.	Too frequent defrosting.	No air flow or air flow too low. Inlet/outlet opening for air blocked. Air duct closed or blocked. Pressure drop too high (air duct too long or too many bends installed). Evaporator soiled.	Set fan to maximum speed (menu: "FAN MODE 2"). Check that air is routed correctly through device. Check length of duct: (6 m out and back for flexible air duct; 12 m out and back for rigid air duct). Check air ducts to ensure any additional air filters installed are not soiled.	Domestic hot water heat pump off. Supplementary electric heating system heats up water to 43 °C (min. 38 °C)
LOW PRES.	Low pressure on heat pump.	No air flow or air flow too low. Inlet/outlet opening for air blocked. Air duct closed or blocked. Fan blocked or not working. Evaporator soiled or blocked. Evaporator iced up.	Check whether fan is running (caution - rotating parts). Check that air is routed correctly through entire air duct. Check length of duct. Check air ducts to ensure that any additional fir filters installed are not soiled. Check whether evaporator is soiled or blocked.	Domestic hot water heat pump off. Supplementary electric heating system heats up water to 43 °C (min. 38 °C)
OVER HEAT	Excessive domestic hot water temperature (water temperature > 85°C).	Domestic hot water sensor faulty. Domestic hot water sensor not in cylinder. Heating element for supplementary electric heating covered with limescale.	Check whether domestic hot water sensor is fitted correctly in the cylinder. Carefully remove limescale from heating element or replace heating element.	Domestic hot water heat pump off. Automatic restart of domestic hot water heat pump if temperature falls below set domestic hot water set temperature.

Display	Type of fault	Cause	Measures required	Temporary Function / Resolution
ERR.01	Temperature sensor measured results incorrect.	Air and defrost sensor connections reversed on board. Domestic hot water and defrost sensor connections reversed on board.	Replace sensor connection on board.	Domestic hot water heat pump off.
	Defrost sensor measured result incorrect.	Falsified measured values due to loose, uninsulated defrost sensor in refrigeration circuit.	Install defrost sensor securely in refrigeration circuit and insulate properly.	
	Refrigerant low.	Leakage in refrigeration circuit.	Find and seal leakage (solder). Fill refrigeration circuit with refrigerant quantity specified in device information (only to be carried out by qualified refrigeration engineer)	
	Expansion valve faulty.	Expansion valve faulty or sensor break on expansion valve.	Replace expansion valve.	
	Compressor not working. Minimum water temperature "T°C MINI" enabled.	Compressor faulty.	Replace compressor.	
ERR.02	Temperature sensor measured results incorrect.	Air and domestic hot water sensor connections reversed on board.	Replace sensor connection on board.	Domestic hot water heat pump off.
ERR.03	Temperature sensor measured results incorrect.	Air, defrost and/or domestic hot water sensor connections reversed.	Replace sensor connection on board.	Domestic hot water heat pump off.
ERR.04	Defrost sensor and domestic hot water sensor measured results incorrect.	Defrost and domestic hot water sensor connections reversed on board.	Replace sensor connection on board.	Domestic hot water heat pump off.
ALARM EPrO	Software fault on display board.	Display board faulty.	Replace display and board.	Domestic hot water heat pump off.
ERR.08	Defrost sensor measured result incorrect.	Defrost sensor faulty.	Replace sensor.	Domestic hot water heat pump in alternative operation (el. supplementary heating or 2nd heat generator).

Display	Type of fault	Cause	Measures required	Temporary Function / Resolution
ANTI BACT.	Thermal disinfection cannot be enabled.	Current domestic hot water withdrawal volume too high.	Stop water withdrawal and restart thermal disinfection.	Domestic hot water heat pump in normal operation.
		Domestic hot water set temperature too high.	Adjust domestic hot water set temperature in "WATER TEMP" menu.	
		Malfunction on additional heating element.	Clean heating elements for supplementary electric heating (remove limescale) and/or reset safety temperature limiter on heating element.	
		Supplementary electric heating not enabled.	Enable supplementary electric heating.	

If you are unable to resolve the fault yourself, and for any work on the electrical system, the hydraulics or the refrigeration circuit, contact your specialist engineer or our after-sales service.

⚠ ATTENTION!

Any undocumented work on the device represents a modification and results in all entitlements to regress and warranty claims being void. Every component replacement must be performed by specialist personnel using genuine spare parts from the manufacturer.

12.3. Decommissioning

Temporary decommissioning of the device

i NOTE

For longer temporary decommissioning of the device, the cylinder must be emptied and the domestic hot water heat pump protected against frost.

Permanent decommissioning of the device

i NOTE

The device must be decommissioned by a specialist engineer.

12.4. Disposal

⚠ ATTENTION!

The device must be de-energized before decommissioning and dismantling.

⚠ ATTENTION!

During decommissioning of the domestic hot water heat pump, all environmental requirements regarding recovery, recycling and disposal of operating materials and components should be observed in compliance with EN 378.



The device must not be disposed of as household waste, but must be taken to a local disposal point.

Store removed domestic hot water heat pumps in a dry location throughout the entire disposal chain, as otherwise operating materials may enter the groundwater.

Disposal of refrigerant

i NOTE

The device contains the refrigerant R290 (propane).

i NOTE

The refrigerant must always be disposed of by a specialist.

12.5. Drainage

- Disconnect the device from the power supply.
- Shut off the cold water supply, open the domestic hot water and drainage taps. Make sure that air can flow through to ensure complete drainage of the cylinder.

12.6. Spare parts list

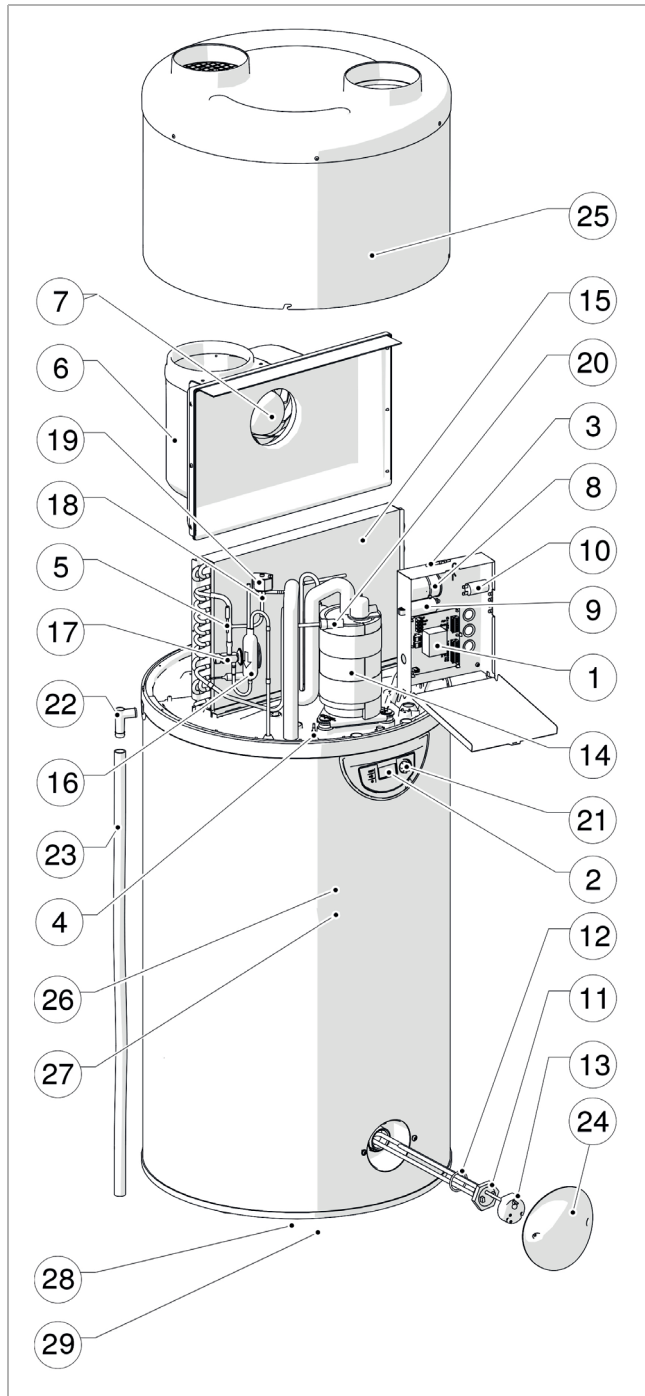

i NOTE

The individual parts that our products are equipped with are supplied for a period of 10 years from the termination of series production.

12.6.1. Control and displays

No.	Article no.	Designation
1	451906.41.26	Motherboard C3S
2	451906.41.27	Display, complete with software DHW 301P
	451906.41.28	Display, complete with software DHW 301P+
3	451906.41.29	Air sensor, length 460 mm
4	451906.41.30	Domestic hot water sensor, length 1200 mm
5	451906.41.31	Defrost sensor set

12.6.2. Electrical equipment

No.	Article no.	Designation
6	451906.41.32	Fan housing
7	451906.41.33	AC fan Ø 190
8	451906.41.06	Condenser 15 µF
9	451906.41.34	Condenser 5.5 µF
10	451906.41.35	Condenser 2 µF
19	451906.41.36	Coil, length 650 mm
*	451906.41.37	Supply cable

* Not visible

12.6.3. Refrigeration circuit components

No.	Article no.	Designation
14	451906.41.13	Compressor kit
15	451906.41.38	Evaporator
16	451906.41.15	Filter dryer
17	451906.41.16	Thermostatic expansion valve
18	451906.41.39	Solenoid valve with filter
20	451906.41.17	Pressure switch

12.6.4. Supplementary electric heater

No.	Article no.	Designation
11	451906.41.10	Heating element 1200 W including seal
12	451906.41.11	Heating element seal
13	451906.41.12	Thermostat

12.6.5. Covering

No.	Article no.	Designation
21	451906.41.40	Display dial
22	451906.41.18	T-piece for condensate drain
23	451906.41.19	Condensate drain hose 18 x 23, length 1.8 m
24	451906.41.20	Heating element cover plate
25	451906.41.41	Upper hood, insulated
26	451906.41.23	Sacrificial anode Ø 33 mm, length 400 mm
27	451906.41.22	Anode cover plate
28	451906.41.24	Lower cylinder flange cover
29	451906.41.25	Flange seal for flange no. 28

13. Service

Service and technical support

After-sales service, technical support and spare parts.

Assistance before and after installation of your equipment.

Phone: +49 9221 709 545

Fax: +49 9221 709 924545

Mon - Thu: 7:00 to 17:00

Fri: 7:00 to 15:00

E-mail: service@dimplex.de

Internet: www.dimplex.de

www.dimplex.de/garantieverlaengerung

www.dimplex.de/serviceauftrag

Request after-sales service on the internet:

www.dimplex.de/dimplex-service

For order processing, the type, the serial number, the date of manufacture (FD) and, if specified, the customer service index (KI) for the device are required. This information is listed on the type plate of the device.

Contact

Glen Dimplex Deutschland GmbH

Am Goldenen Feld 18

95326 Kulmbach

Germany

Phone: +49 9221 709 101

Fax: +49 9221 709 339

E-mail: info@dimplex.de

Internet: www.dimplex.de

Austrian branch

Glen Dimplex Austria GmbH

Hauptstraße 71

5302 Henndorf am Wallersee, Austria

Phone: +43 6214 203 30

E-mail: info@dimplex.at

Internet: www.dimplex.at

14. Technical data

14.1. Power heat pump

		DHW 301P	DHW 301P+
Usable capacity	l	270	265
Maximum power (HP* + supplementary heater)	W	1900	
Air temperature range	°C	-7 to +45	
Hot water temperature* with heat pump	°C	30 to 60	
Power consumption of the heat pump, max.*	W	700	
Air flow	m ³ /h	320 to 400	
Sound power level internal**	dB(A)	49.8	
Sound power level external**	dB(A)	37.9	
Refrigerant	-/kg	R 290 / 0.15	
GWP value (CO ₂ equivalent)	kg	0.45 kg CO ₂	
Technical air connection type	-	Outdoor or surrounding air (min. 20 m ³)	

14.2. Standard data EN 16147

		DHW 301P	DHW 301P+
Withdrawal cycle	-	XL	
COP* (outside air +7 °C)	-	3.1	3.05
Power consumption on standby	W	25	
Reference domestic hot water temperature	°C	53.8	
Heat-up time	-	10.24	10.27
Energy efficiency class	-	A+	
Seasonal energy efficiency	%	129	125
V _{max}	l	349.3	
V _{40 td}	l	353	372
COP* (indoor air +15 °C)	-	3.51	
Q _(elec)	kWh	6.02	6.24

14.3. Dimensions and connections

		DHW 301P	DHW 301P+
Dimensions	mm	630 x 1812	
Weight (empty)	kg	83	93
Air connection diameter (intake/outlet side)	mm	160	
Air duct length, max.	m	Flexible pipe: 6 m Smooth pipe: 12 m (intake and outlet)	
CW and DHW connection diameter, circulation	Inch	R 3/4"	
Power supply	V/Hz/A	230 V/50 Hz/8 A	
Degree of protection	-	IPX4	
Circuit breaker (curve D)	A	8	
Tilting dimension	mm	1890	
Surface area/connection Additional heat exchanger	m ² /inch	-	0.9 / Rp 1"

14.4. Cylinder

		DHW 301P	DHW 301P+
Materials and protection	-	Enamelled steel with sacrificial anode	
Operating pressure, max.	MPa	0.6 (6 bar)	
Condensate throughput, max.	l/h	0.3	
Power integrated additional electric heating (Safety = 85 °C)	W	1200	
Temperature with additional electric heating	°C	65	70

* DHW = Domestic hot water

* HP = Heat pump

* CW = Cold water

* COP = Coefficient of performance

** Sound pressure tested in a low-reflection room

14.5. Dimensions

⚠ ATTENTION!

Heavy shipping weight. Risk of tipping over!

Dimensions DHW 301P

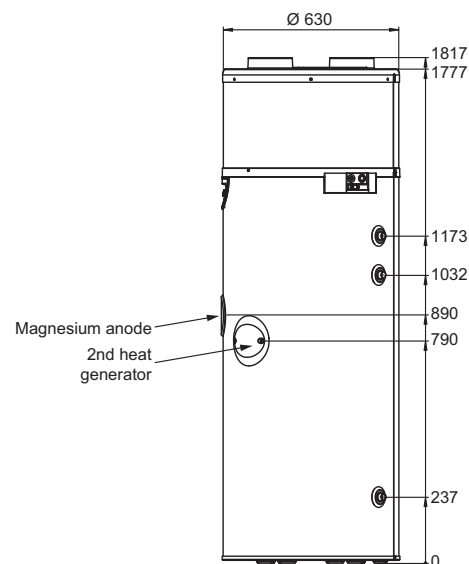

Dimensions DHW 301P+

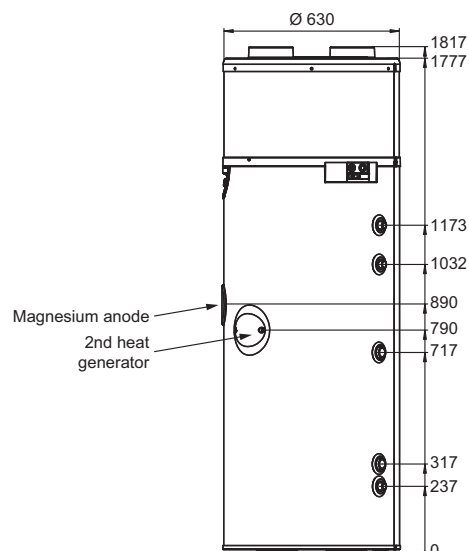

Connection diagram DHW 301P(+) with 2nd heat generator

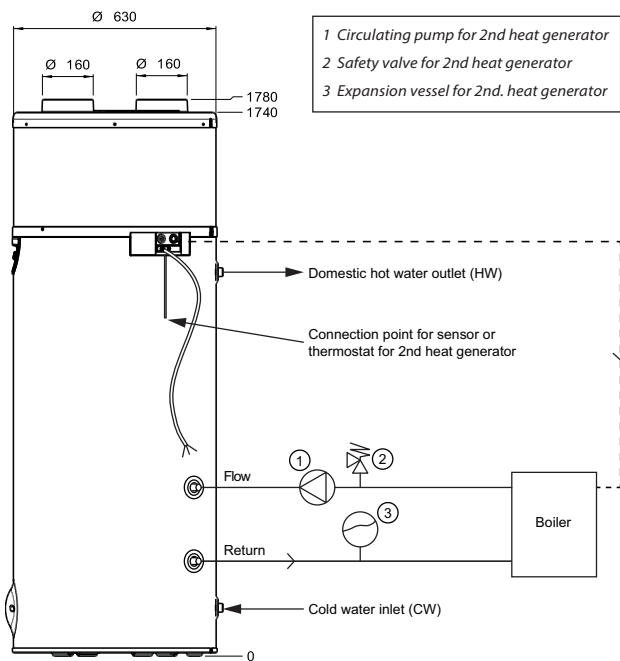

14.6. Performance diagrams

14.6.1. COP diagram

The heat output and the resulting COP value have been measured in compliance with EN 16147 at a water inlet temperature of 10 °C. The COP values depending on the air intake temperature are shown in the following diagram.

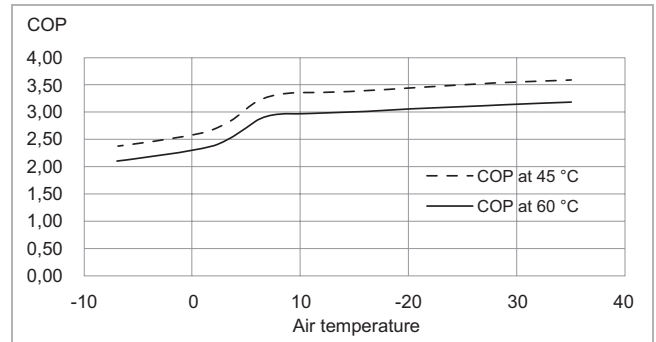

14.6.2. Heating-up time

The diagram below shows the heating-up time at different air intake temperatures for full loading of the cylinder with 45 °C or 60 °C domestic hot water in pure heat pump operation (without additional electric heating).

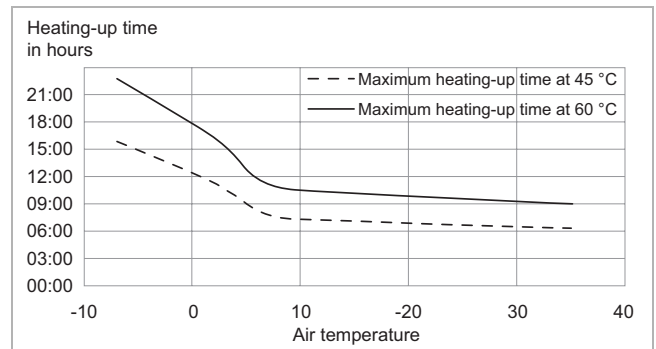

14.7. NTC 10 sensor characteristic curve

All sensors in the domestic hot water heat pump have the same characteristic curve.

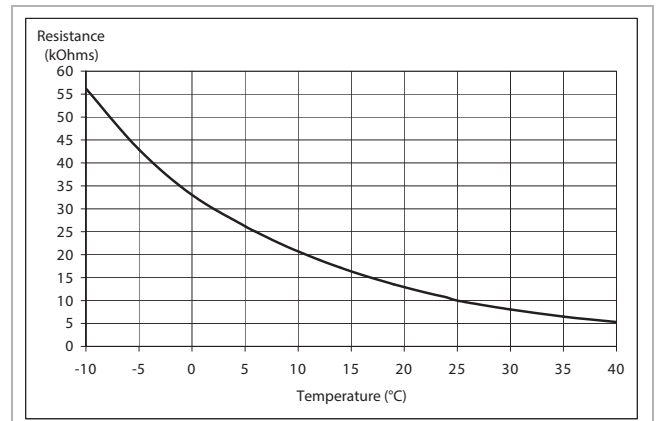

Glen Dimplex Deutschland GmbH
Am Goldenen Feld 18
95326 Kulmbach, Germany

Phone: +49 9221 709 545
Fax: +49 9221 709 924545
E-mail: service@dimplex.de